

— Restoration & Moisture & Ventilation —

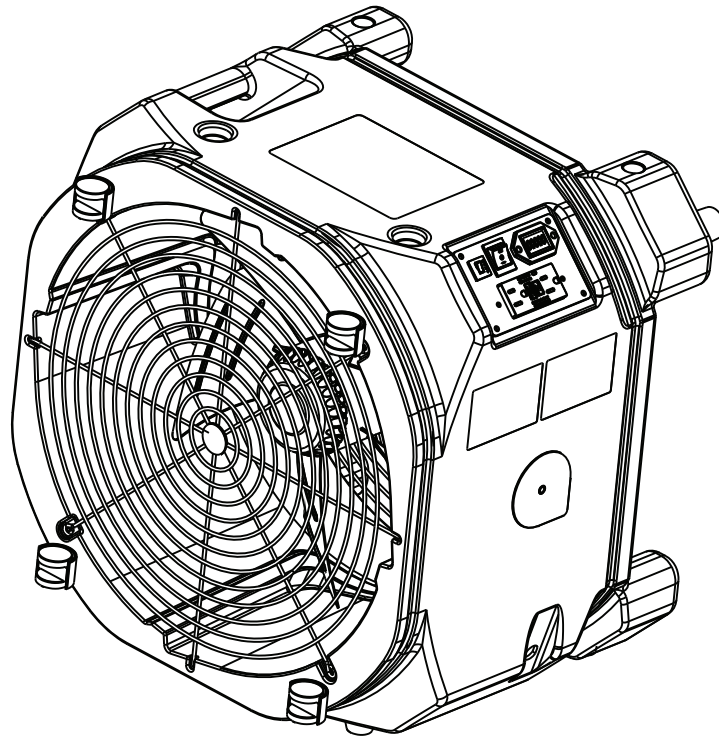

Zeus Extreme Owner's Manual



Read and Save These Instructions

Seaira Global LLC

14021 NC Highway 50 Surf City, NC 28445

910-660-0962 sales@seairaglobal.com

Safety Notes

WARNING:

- Do not adjust or alter the unit in any way. Only use the parts approved by AlorAir. Any adjustments or use of unauthorized parts will void your warranty. For further assistance, contact your dealer or distributor.
- Do not let children play with unit. Always keep the unit out of reach of children.
- Do not restrict airflow to unit.
- Do not use unit with extension cords.
- Do not use an external speed control device.
- Do not drop or throw the unit. This could damage the inner parts and wiring.
- Do not use the unit in standing water.
- Do not use the unit outside as the internal components may get damp.
- Do not use air mover with a malfunctioning outlet or plug.
- Do not run power cord under carpet, runners, or other coverings.

While Operating the Zeus Extreme:

- Always use a grounding plug and grounded electric outlet to reduce risk of fire and shock.
- Always use caution when stacking units to prevent them from falling. Avoid stacking units in crowded areas.
- Always secure units during transportation to prevent them from moving.
- Always maintain a reasonable distance between the air inlet and carpets or other materials. Failure to do so may clog the inlet or cause overheating.
- Always keep the motor free of dirt, dust, and other particles that could cause the motor to overheat. Clean the motor with a vacuum if it gets dirty.
- Always unplug the machine before performing any maintenance.
- Always contact an authorized technician for help repairing your machine.
- Always use the unit on a level, steady surface.

Specifications

Drive Motor	1/4 hp 1-phase 110/120 VAC 2-speed 4-pole, PSC Electric Motor
Voltage	115 VAC
Current	2.5 Amps (High Speed)
Power Cord	20'
Outlet	15A UL Rated GFCI Duplex
Air Flow	Approx. 3000 CFM
Sound Level	<75 dBa
Weight	26 lbs
Dimensions (WxHxD)	19.37" x 20" x 15.5"

Getting Started

The Zeus Extreme air mover blows high velocity air over wet surfaces to shorten the drying time. In addition to accelerating evaporation, the Zeus also helps prevent mold and mildew. To use the air mover, simply direct the air outlet to the targeted area.

Identification

Congratulations on purchasing a Zeus Extreme air mover. In order to take advantage of the warranty plan, be sure to note the serial number and date of purchase.

Serial Number:

Date of Purchase:

Electrical Connection

- Only connect the machine to 115V/60Hz outlet
- Ensure the electrical outlet is grounded

Linking Multiple Machines

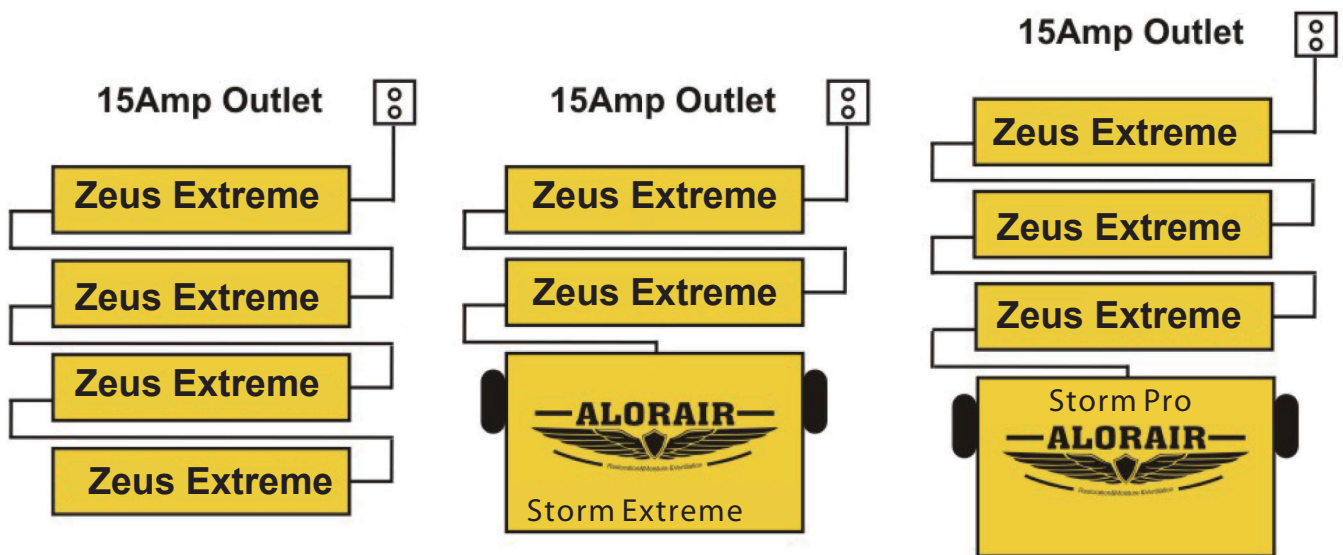

NOTE: The Zeus Extreme plugs into standard 115 VAC electrical outlets.

Each Zeus Extreme air mover draws 2.5 amps and is equipped with a 12 amp circuit board. This means that you can link up to 4 units to run on the same circuit. When daisy chaining the units, always turn on one unit at a time rather than starting all units simultaneously, which could cause the circuit to short.

Humidity Control

While using an air mover to dry the air, you may find out that the humidity is rising. To avoid this, it is useful to pair the air mover with a dehumidifier. A dehumidifier can effectively control the humidity level, while also reducing the drying time. For mold control, the ideal humidity level is below 60% RH.

Temperature & Air Circulation

To cool down a warm room, place the Zeus Extreme at the doors or in a cooler spot with air directed at the hot area. If set up properly, the high velocity air from the machine can cool a room down quite effectively.

Set Up

The Zeus Extreme can be operated in multiple positions, depending on what direction you need to target the airflow.



◀ Tilt Back – This position will create laminar airflow to the floor.



◀ Tilt Forward – This position will direct air upwards.



◀ Face Down – This position will send air directly to the floor.



- ◀ Face Up – This position will direct air straight to the ceiling.



- ◀ Stacked for Operation – This gives you the opportunity to run two units simultaneously.

NOTE: Always ensure units are stable and on a level surface when stacking them.



- ◀ Stacked for Storage – The units can also be stacked sideways for storage if space is limited.

NOTE: Units can not be operated in this position.

Operating Instructions

1. Connect the air mover to a standard 115V/60Hz outlet.
2. Place the unit in the desired position.
3. Use the switch on the control panel to select your speed (high or low).
4. Refrain from moving the unit during operation.

Maintenance

NOTE: All maintenance procedures should be performed with the unit unplugged.

Check Electrical Components

Remove the housing and check for issues such as power cord damage, bare wires, insecure fasteners, and discoloration.

NOTE: Repair any damaged wiring as soon as possible to avoid a fire hazard or risk of electrical shock.

Check External Components

Evaluate the the exterior of the machine and ensure all parts are in place. Repair or replace any parts as needed.

Clean the Grills

Wipe off any dust or particulate accumulation on the grill. If there is an accumulation of dust on the grill, it will restrict the air flow, which may cause the electric motor to overheat.

Clean the Exterior

Clean the outside with a gentle cleanser and water.

Warranty

All warranty benefits apply to the original owner only. Warranty cannot be transferred or assigned.

1 Year (from date of purchase): Seaira Global warrants the machine will operate free of defects in workmanship and materials. At it's discretion, Seaira will repair or replace any malfunctioning components, free of charge (excluding transportation costs)

Customer Responsibilities: In order to take advantage of the warranty service, the customer must do the following:

1. Customer must provide normal care and maintenance (including, but not limited to cleaning filters)
2. Removal and re-installation of unit is the sole responsibility of owner.
3. If customer cannot return unit to certified repair center, all costs associated with shipment are borne by the customer. In addition, all ancillary charges related to freight shipments, including but not limited to palletizing, wrapping, labeling, and pickup are associated with customer.
4. If shipped, customer is responsible for all risk of loss or damage.

Warranty Procedure:

1. Customer must mail in warranty registration card to Seaira Global. If no card is submitted, warranty period will begin the day the shipment left the warehouse. Please be sure to record serial # and date of installation. You will need this information to receive an RA number.
2. If warranty service is necessary, customer must contact Seaira Global Tech Support by phone 910-660-0962 to receive a Return Authorization (RA number).
3. Once an RA has been issued, it is the customer's job to bring the unit to a certified repair center. If this is not an option, shipping will be arranged to bring the unit back to the Seaira warehouse (at the expense of the customer).
4. After the unit has been received by Seaira (whether at a repair center or the warehouse), an initial inspection will be completed, if it is determined to be an invalid warranty claim (see exclusions below), unit will be only be completed after receiving payment from customer for all associated costs.
5. If unit is defective, the necessary parts will be repaired or replaced and the unit will be available for pickup at certified repair center or returned via freight shipment (at customer's expense). Keep in mind that work is only done during normal working hours. After being repaired, all units are required to go through a rigorous testing process prior to being returned to customer.
6. Once a part is repaired and the dehumidifier is returned, the original warranty period still applies (no extensions).

Warranty Exclusions:

DAMAGE DUE TO THE FOLLOWING IS NOT covered under warranty

1. Acts of Nature- including but not limited to:
flooding
fire
water damage
hurricane/storm damage
2. IMPROPER USAGE- Including but not limited to:
misuse, abuse, or tampering whether intentional or accidental
improper installation or design
improper voltage
lack of normal care
failure to follow instructions
3. Corrosion
4. Freezing
5. any additional costs due to changes in laws or building codes
6. freight charges
7. any costs due to lost profit or delay
8. damage to property
9. cause beyond control
10. consumable parts, including but not limited to:
filters
batteries
power cords
valves
switches
rubber parts
11. direct, indirect, collateral or inconsequential damages of any kind

THE WARRANTIES AND LIABILITIES SET FORTH ARE IN LIEU OF ALL OTHER WARRANTIES EXPRESSED OR IMPLIED, IN LAW OR IN FACT, INCLUDING IMPLIED WARRANTIES OF MERCHANTABILITY AND FITNESS FOR PARTICULAR PURPOSE. SEAIRA Global's total liability, regardless of nature of claim shall not exceed original purchase price of the product. If a product or component is replaced while under warranty, the applicable warranty period shall not be extended beyond the original warranty time period.

The foregoing shall constitute the total liability of seller in the case of defective performance of all or any of the equipment or services provided to Buyer. Buyer agrees to accept and hereby accepts the foregoing as the sole and exclusive remedy for any breach or alleged breach of warranty by Seller.

Any dishonesty or fraud in connection with SEAIRA GLOBAL warranty thoroughly voids all warranty policies. SEAIRA Global expressly reserves the right to pursue legal action in the event of dishonesty, fraud, or attempted fraud.